



10623 Roselle Street, San Diego, CA 92121 • (858) 550-9559 • FAX (858) 550-7322  
contactus@acesio.com • www.acesio.com

**MODEL 104-DA12-8**  
**Analog Output Board**  
**USER MANUAL**

FILE: M104-DA12-8.A1e

## Notice

The information in this document is provided for reference only. ACCES does not assume any liability arising out of the application or use of the information or products described herein. This document may contain or reference information and products protected by copyrights or patents and does not convey any license under the patent rights of ACCES, nor the rights of others.

IBM PC, PC/XT, and PC/AT are registered trademarks of the International Business Machines Corporation.

Printed in USA. Copyright 2001, 2007 by ACCES I/O Products, Inc. 10623 Roselle Street, San Diego, CA 92121. All rights reserved.

## WARNING!!

**ALWAYS CONNECT AND DISCONNECT YOUR FIELD CABLING WITH THE COMPUTER POWER OFF. ALWAYS TURN COMPUTER POWER OFF BEFORE INSTALLING A BOARD. CONNECTING AND DISCONNECTING CABLES, OR INSTALLING BOARDS INTO A SYSTEM WITH THE COMPUTER OR FIELD POWER ON MAY CAUSE DAMAGE TO THE I/O BOARD AND WILL VOID ALL WARRANTIES, IMPLIED OR EXPRESSED.**

## **Warranty**

Prior to shipment, ACCES equipment is thoroughly inspected and tested to applicable specifications. However, should equipment failure occur, ACCES assures its customers that prompt service and support will be available. All equipment originally manufactured by ACCES which is found to be defective will be repaired or replaced subject to the following considerations.

### **Terms and Conditions**

If a unit is suspected of failure, contact ACCES' Customer Service department. Be prepared to give the unit model number, serial number, and a description of the failure symptom(s). We may suggest some simple tests to confirm the failure. We will assign a Return Material Authorization (RMA) number which must appear on the outer label of the return package. All units/components should be properly packed for handling and returned with freight prepaid to the ACCES designated Service Center, and will be returned to the customer's/user's site freight prepaid and invoiced.

### **Coverage**

First Three Years: Returned unit/part will be repaired and/or replaced at ACCES option with no charge for labor or parts not excluded by warranty. Warranty commences with equipment shipment.

Following Years: Throughout your equipment's lifetime, ACCES stands ready to provide on-site or in-plant service at reasonable rates similar to those of other manufacturers in the industry.

### **Equipment Not Manufactured by ACCES**

Equipment provided but not manufactured by ACCES is warranted and will be repaired according to the terms and conditions of the respective equipment manufacturer's warranty.

### **General**

Under this Warranty, liability of ACCES is limited to replacing, repairing or issuing credit (at ACCES discretion) for any products which are proved to be defective during the warranty period. In no case is ACCES liable for consequential or special damage arriving from use or misuse of our product. The customer is responsible for all charges caused by modifications or additions to ACCES equipment not approved in writing by ACCES or, if in ACCES opinion the equipment has been subjected to abnormal use. "Abnormal use" for purposes of this warranty is defined as any use to which the equipment is exposed other than that use specified or intended as evidenced by purchase or sales representation. Other than the above, no other warranty, expressed or implied, shall apply to any and all such equipment furnished or sold by ACCES.

# Table of Contents

|  |    |
|--|----|
| <b>Chapter 1: Overview</b> .....                             | 5  |
| <b>Figure 1-1: Block Diagram</b> .....                       | 6  |
| <b>Chapter 2: Installation</b> .....                         | 7  |
| <b>Figure 2-1: PC/104 Key Information</b> .....              | 8  |
| <b>Chapter 3: Option Selection</b> .....                     | 9  |
| <b>Table 3-1: Base Address Jumpers</b> .....                 | 9  |
| <b>Table 3-2: Standard Address Assignments</b> .....         | 10 |
| <b>Figure 3-1: Option Selection</b> .....                    | 11 |
| <b>Chapter 4: Programming</b> .....                          | 12 |
| <b>Table 4-1: Register Map</b> .....                         | 12 |
| <b>Chapter 5: Software</b> .....                             | 15 |
| <b>Chapter 6: Connector Pinouts</b> .....                    | 16 |
| <b>Table 6-1: Connector P1, 40-pin Male IDC Header</b> ..... | 16 |
| <b>Table 6-2: Connector P2, 10-pin Male IDC Header</b> ..... | 17 |
| <b>Table 6-3: Connector P4, 8-pin Male IDC Header</b> .....  | 18 |
| <b>Figure 6-1: Signal Connection</b> .....                   | 18 |
| <b>Appendix A: Technical Specifications</b> .....            | 19 |
| <b>Appendix B: 82C54 Counter Timer Operation</b> .....       | 20 |

# Chapter 1: Overview

## Features

- Eight 12-Bit 10uS Digital to Analog Converters
- Counter/Timer with a 32-bit Divisor for Conversion Triggers
- Counter/Timer with a 16-bit Divisor for Interrupts
- 4-20mA Current Sink

## Circuit Description

The board has eight 12-bit digital to analog converters. The circuit uses an Analog Devices AD5348 which has a single 12-bit input port, a 3-bit address port, and a shared 'start conversion' signal. The outputs are buffered by eight op-amps.

Two countdown timers (based on an i8254) are provided. The output of Counter/Timer 0 (16 bit, see appendix B) is available at connector P2 pin 4. The output of chained timers 1 & 2 (32 bit) provide the conversion trigger. The 16-bit timer has a 10MHz clock input while the 32-bit trigger timer has a 2MHz clock input, either may generate an interrupt.

The board has a 4-20mA current sink outputs. Each DAC may drive a 4-20mA sink with digital values from 0 (4mA) to 4095 (20mA). This is in addition to and in parallel with the op-amp driven outputs. The current is regulated with FETs, each source lead connects to the card's ground plane through a small resistance and each drain lead connects to the user's circuit.

A 4.096 volt reference is available at a connector pin (J1 Pin 35). Fused (resettable) +5 volts from the PC/104 bus and fused (resettable) +12 volts are also available. The +12 volts may come from the user's power supply if the PC/104 bus doesn't have it (some don't).

Note that on power-up the 4.096V reference is in standby mode. This ensures that all D/AC outputs are at zero volts. The user must set bit 6 at the card's base address +10h. Clearing this bit at any time will cause all outputs to go to zero.

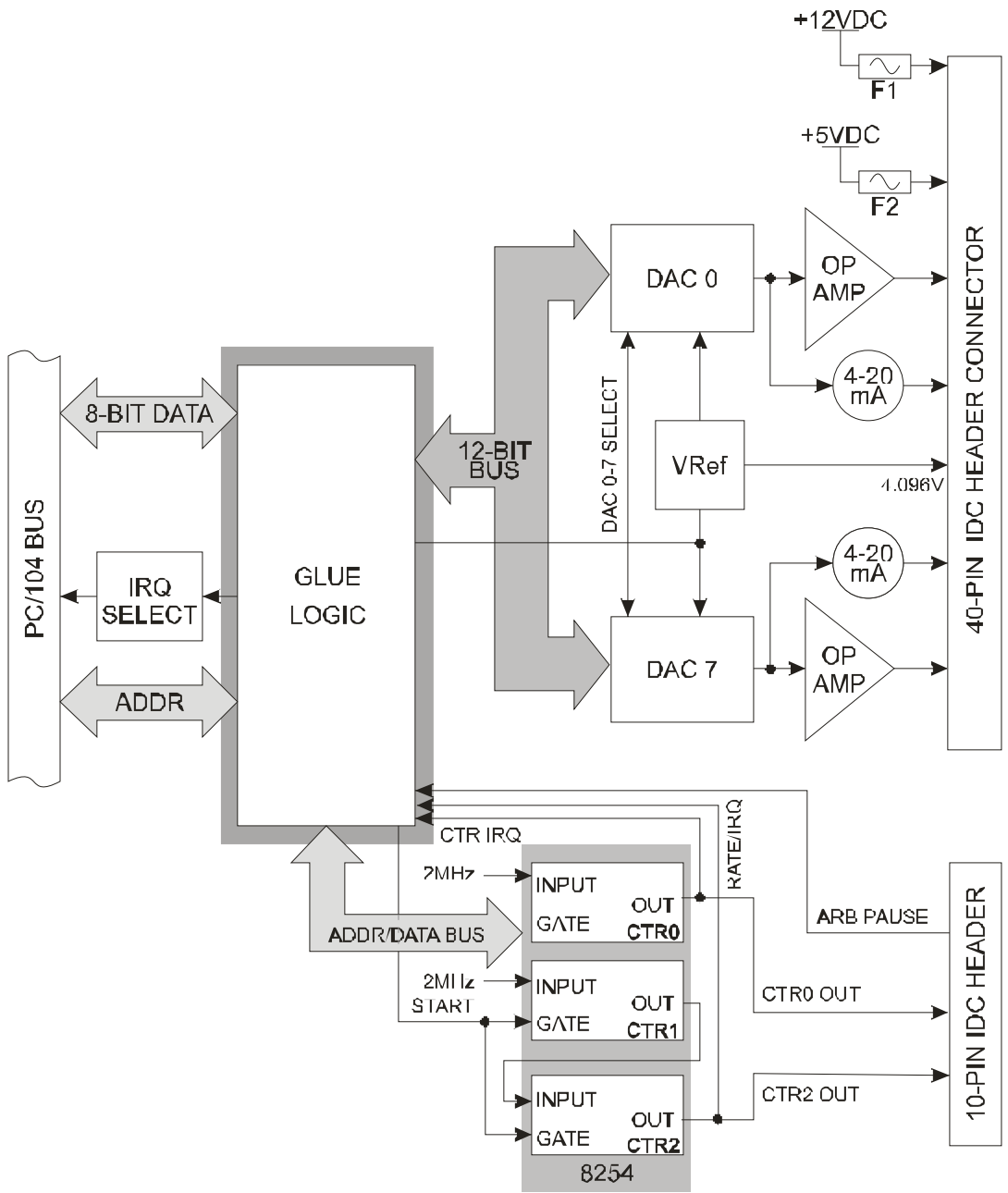

Figure 1-1: Block Diagram

# Chapter 2: Installation

A printed Quick-Start Guide (QSG) is packed with the board for your convenience. If you've already performed the steps from the QSG, you may find this chapter to be redundant and may skip forward to begin developing your application.

The software provided with this PC/104 Board is on CD and must be installed onto your hard disk prior to use. To do this, perform the following steps as appropriate for your operating system. Substitute the appropriate drive letter for your CD-ROM where you see d: in the examples below.

## CD Installation

The following instructions assume the CD-ROM drive is drive "D". Please substitute the appropriate drive letter for your system as necessary.

### DOS

1. Place the CD into your CD-ROM drive.
2. Type `D:\>Enter` to change the active drive to the CD-ROM drive.
3. Type `I N S T A L L Enter` to run the install program.
4. Follow the on-screen prompts to install the software for this board.

### WINDOWS

1. Place the CD into your CD-ROM drive.
2. The system should automatically run the install program. If the install program does not run promptly, click START | RUN and type `D:\I N S T A L L`, click OK or press `Enter`.
3. Follow the on-screen prompts to install the software for this board.

### LINUX

1. Please refer to linux.htm on the CD-ROM for information on installing serial ports under linux.

## Installing the Hardware

Before installing the board, carefully read Chapter 3 and Chapter 4 of this manual and configure the board according to your requirements. The SETUP Program can be used to assist in configuring jumpers on the board. Be especially careful with Address Selection. If the addresses of two installed functions overlap, you will experience unpredictable computer behavior. To help avoid this problem, refer to the FINDBASE.EXE program installed from the CD. The setup program does not set the options on the board, these must be set by jumpers.

### To Install the Board

1. Install jumpers for selected options and base address according to your application requirements, as mentioned above.
2. Remove power from the PC/104 stack.
3. Assemble standoff hardware for stacking and securing the boards.
4. Carefully plug the board onto the PC/104 connector on the CPU or onto the stack, ensuring proper alignment of the pins before completely seating the connectors together.
5. Install I/O cables onto the board's I/O connectors and proceed to secure the stack together or repeat steps 3-5 until all boards are installed using the selected mounting hardware.
6. Check that all connections in your PC/104 stack are correct and secure then power up the system.
7. Run one of the provided sample programs appropriate for your operating system that was installed from the CD to test and validate your installation.

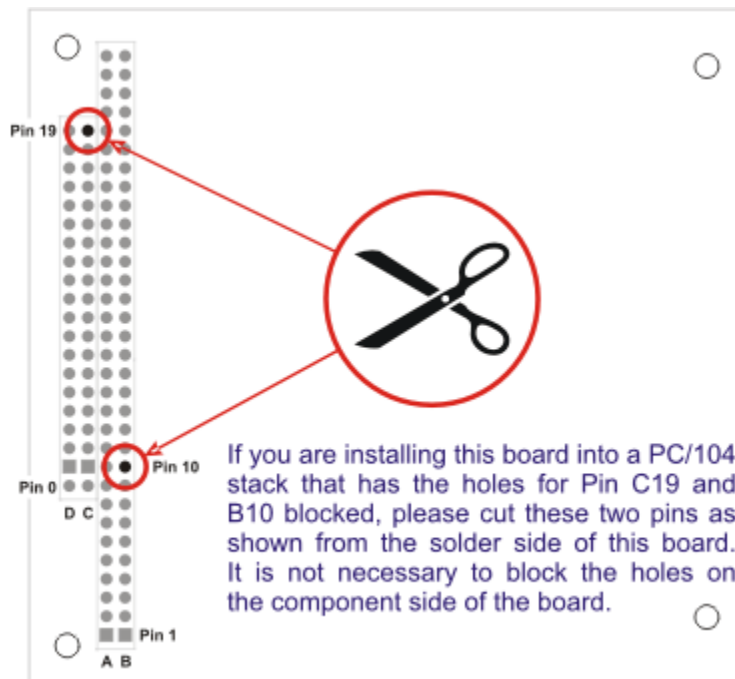

**Figure 2-1: PC/104 Key Information**

# Chapter 3: Option Selection

Jumpers are available on the card to setup the following:

- Base address
- IRQ level
- DAC output voltage ranges

## Address Selection

The Card's Base Address is set by jumpers marked /A5 through /A9, and /A5 is the least significant bit of the address. The base addresses can be selected anywhere within the I/O address range 000-3E0 provided that they do not overlap with other functions. The FINDBASE software utility provided on the CD with your card will help you select a base address that does not conflict with other assignments.

This card requires a block of 32 addresses (20 hex). In order to configure the desired address, the hexadecimal address must be converted to a binary representation which is then selected by installing jumpers on the card.

For example, as illustrated below, switch selection corresponds to hex **2C0 (or binary 10 110x xxxx)**. The "xxxx" represents address lines A4 through A0 used on the card to select individual registers.

| Hex Representation    | 2  |     | C  |    |     |
|-----------------------|----|-----|----|----|-----|
| Conversion Factors    | 2  | 1   | 8  | 4  | 2   |
| Binary Representation | 1  | 0   | 1  | 1  | 0   |
| Jumper Installed      | NO | YES | NO | NO | YES |
| Jumper Label          | A9 | A8  | A7 | A6 | A5  |

**Table 3-1: Base Address Jumpers**

Please note that "1" means that no jumper is installed and that "0" means that a jumper must be installed.

**Consult the documentation for your system before selecting a card address.**

The board occupies 32 bytes of I/O space. The board base address can be selected anywhere within the I/O address range 0-3E0 hex. If in doubt of where to assign the base address, refer to the following tables and the FINDBASE program to find an available address for your system.

| HEX RANGE | USAGE                            |
|-----------|----------------------------------|
| 000-00F   | 8237 DMA Controller 1            |
| 020-021   | 8259 Interrupt                   |
| 040-043   | 8253 Timer                       |
| 060-06F   | 8042 Keyboard Controller         |
| 070-07F   | CMOS RAM, NMI Mask Reg, RT Clock |
| 080-09F   | DMA Page Register                |
| 0A0-0BF   | 8259 Slave Interrupt Controller  |
| 0C0-0DF   | 8237 DMA Controller 2            |
| 0F0-0F1   | Math Coprocessor                 |
| 0F8-0FF   | Math Coprocessor                 |
| 170-177   | Fixed Disk Controller 2          |
| 1F0-1F8   | Fixed Disk Controller 1          |
| 200-207   | Game Port                        |
| 238-23B   | Bus Mouse                        |
| 23C-23F   | Alt. Bus Mouse                   |
| 278-27F   | Parallel Printer                 |
| 2B0-2BF   | EGA                              |
| 2C0-2CF   | EGA                              |
| 2D0-2DF   | EGA                              |
| 2E0-2E7   | GPIB (AT)                        |
| 2E8-2EF   | Serial Port                      |
| 2F8-2FF   | Serial Port                      |
| 300-30F   | reserved                         |
| 310-31F   | reserved                         |
| 320-32F   | Hard Disk (XT)                   |
| 370-377   | Floppy Controller 2              |
| 378-37F   | Parallel Printer                 |
| 380-38F   | SDLC                             |
| 3A0-3AF   | SDLC                             |
| 3B0-3BB   | MDA                              |
| 3BC-3BF   | Parallel Printer                 |
| 3C0-3CF   | VGA EGA                          |
| 3D0-3DF   | CGA                              |
| 3E8-3EF   | Serial Port                      |
| 3F0-3F7   | Floppy Controller 1              |
| 3F8-3FF   | Serial Port                      |

**Table 3-2:** Standard Address Assignments

## IRQ Selection

The board can generate an interrupt on the DAC conversion or on the falling edge of Counter/Timer 0. The IRQ # is selected by a jumper placed on one pair of pins from the group labeled 'IRQ3' through 'IRQ15'. If you do not intend to use the IRQ, do not install a jumper on any IRQ pins. The locations of these jumpers is shown in the Option Selection map, as well as in the Setup Program provided with the card.

**This interrupt can not be shared.**

## DAC Option Selections

Each DAC's op-amp circuit has two jumpers which configure its voltage range. The user may select unipolar or bipolar outputs and 5 or 10 max voltage. In other words, the user may select four output ranges: 0 to 5V, 0 to 10V, -5V to +5V, -10V to +10V.

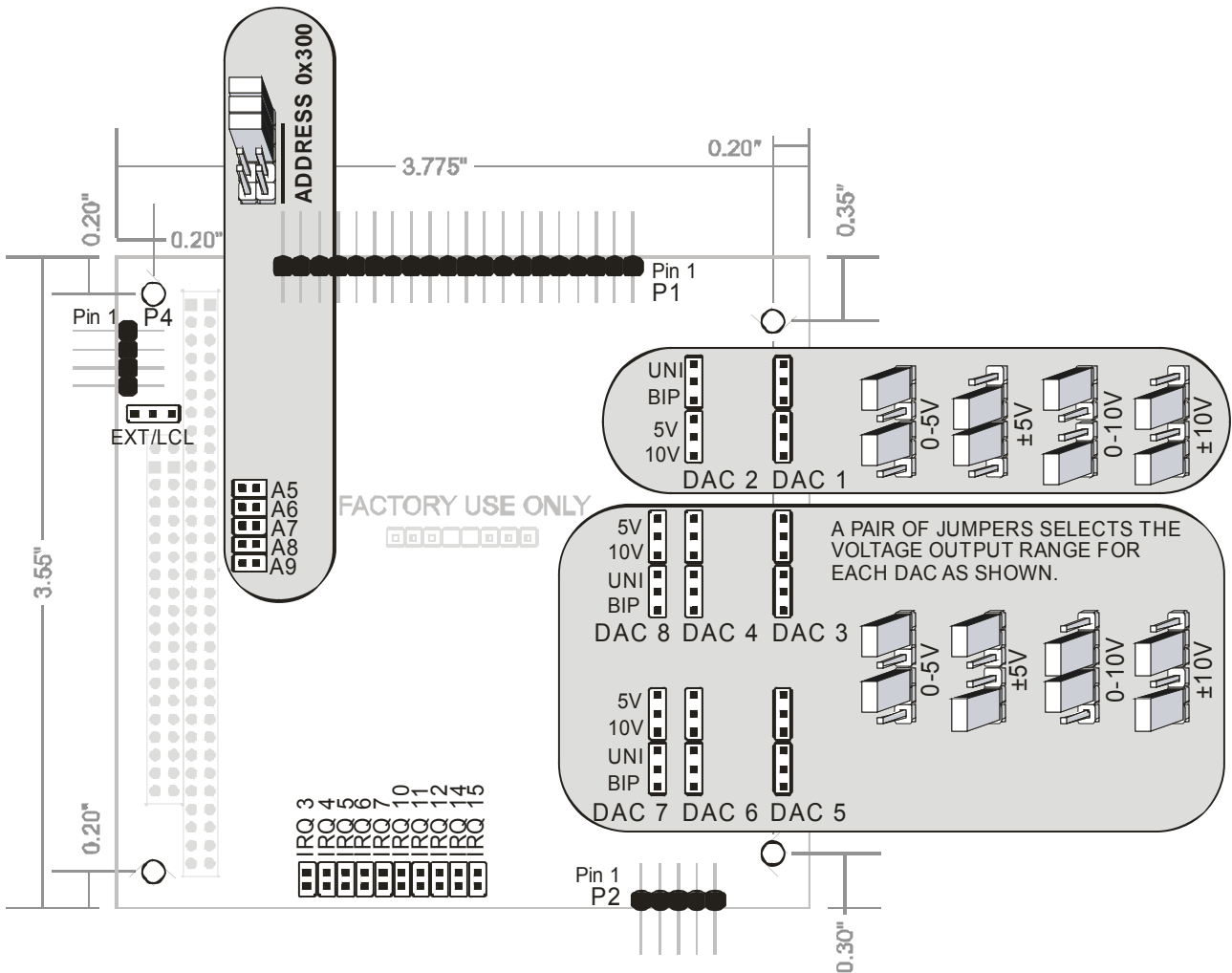

**Figure 3-1: Option Selection**

## Chapter 4: Programming

| Offset | Write Function            | Read Function       |
|--------|---------------------------|---------------------|
| 0      | DAC 0 LSB                 |                     |
| 1      | DAC 0 MSB                 |                     |
| 2      | DAC 1 LSB                 |                     |
| 3      | DAC 1 MSB                 |                     |
| 4      | DAC 2 LSB                 |                     |
| 5      | DAC 2 MSB                 |                     |
| 6      | DAC 3 LSB                 |                     |
| 7      | DAC 3 MSB                 |                     |
| 8      | DAC 4 LSB                 |                     |
| 9      | DAC 4 MSB                 |                     |
| A      | DAC 5 LSB                 |                     |
| B      | DAC 5 MSB                 |                     |
| C      | DAC 6 LSB                 |                     |
| D      | DAC 6 MSB                 |                     |
| E      | DAC 7 LSB                 |                     |
| F      | DAC 7 MSB                 |                     |
| 10     | Voltage REFerence Control |                     |
| 11     | IRQ Enable Register       | IRQ Enable Readback |
| 12     |                           |                     |
| 13     | DAC RESET                 |                     |
| 14     | Program Counter 0         | Read Counter 0      |
| 15     | Program Counter 1         | Read Counter 1      |
| 16     | Program Counter 2         | Read Counter 2      |
| 17     | Counter Control Register  |                     |
| 18     |                           |                     |
| 19     |                           |                     |
| 1A     |                           |                     |
| 1B     |                           |                     |
| 1C     |                           |                     |
| 1D     |                           |                     |
| 1E     | IRQ Clear                 |                     |
| 1F     | Not used                  |                     |

**Table 4-1: Register Map**  
All offsets are in hexadecimal.

## Register Descriptions

The card is controlled by reading and writing 8- or 16-bit registers in I/O Memory. The registers are described below. Please note, all offsets are hexadecimal.

### Base+ 0 through Base + E, DACs 0-7 Direct Control Registers

| D15 | D14 | D13 | D12 | D11 | D10 | D9 | D8 | D7 | D6 | D5 | D4 | D3 | D2 | D1 | D0 |
|-----|-----|-----|-----|-----|-----|----|----|----|----|----|----|----|----|----|----|
| X   | X   | X   | X   | D11 | D10 | D9 | D8 | D7 | D6 | D5 | D4 | D3 | D2 | D1 | D0 |

These 8 word-sized registers allow you to update the DACs from software. If you're interested in simple DC voltage or current outputs you can ignore all the rest of the registers and just use these to control the outputs of the DACs.

Write a word to an even address in the range of (base +) 0 through 0xE to update the DAC with a new count value. Data is offset Binary: 0x0000 is the minimum value (in unipolar modes, 0Volts, in bipolar modes, the most-negative value possible). 0x0800 is the "middle" of the range (0V when in Bipolar modes), and 0x0FFF is the maximum positive voltage.

Bits D15 through D12 are unused and should be set to zero for future compatibility.

To calculate the counts for any given Desired Output Voltage use the following equation:

Given: SpanVolts is equal to the highest positive voltage minus the most negative voltage the range supports (ex: +5V is "5" - "-5" which is "5+5" or "10")

Unipolar: Counts = (DesiredVolts / SpanVolts) \* 4096

Bipolar: Counts = (DesiredVolts / SpanVolts) \* 2048 + 2048

### Base + 10 Write, Reference Control

| D7 | D6  | D5 | D4 | D3 | D2 | D1 | D0 |
|----|-----|----|----|----|----|----|----|
|    | REF |    |    |    |    |    |    |

**Bit D6 REF:** Set/clear to enable/disable the 4.096 DAC REFERENCE. While this bit is set DACs can generate signals, and P1 Pin 35 will have 4.096 volts output. At power-up this bit is cleared and all outputs are 0V.

Bits D0 through D5 and D7 are unused.

Reading this register will return the current state of the Reference Control bit.

All bits in this register power-on or reset to "zero"

**Base + 11 Write, Interrupt Enable Register**

| D7 | D6 | D5 | D4 | D3 | D2 | D1     | D0 |
|----|----|----|----|----|----|--------|----|
|    |    |    |    |    |    | EICTR0 |    |

**Set/clear bits D0 through D7 to enable/disable an irq from each bit's IRQ source.**

**Bit D1 EICTR0:** Enables IRQs from the output of **CounteR 0**. Each time the output of Counter 0 goes low and this bit is set an IRQ will be generated. This counter, and its IRQ and output on the P2 connector (pin 4), are solely for use by the customer.

Reading this register will return the current state of these bits.

All bits in this register power-on or reset to “zero.”

**Base + 13, DAC Reset**

Write any value to this register to clear the DACs and set all outputs to their most negative value. For example, if the range is -10V to +10V on DAC 1 it will go to -10V. If the range on channel 2 is 0V to 5V it will go to zero volts.

**Base + 14, Program Counter/Timer 0 - (see Appendix B)**

This is a 16-bit timer used as a timer-tick for external hardware. Its 10MHz input clock is divided by a load 16-bit value and output on P2 pin 4. This counter output can also generate an IRQ, if enabled (see base + 10.)

**Base + 17, Counter/Timer Control Register - (see Appendix B)**

Use this register to configure the 8254.

**Base + 1E, IRQ Clear**

Write any value to this address to clear a pending interrupt. Once the card generates an IRQ, no further IRQs will be requested until the pending IRQ has been cleared by writing to this address.

## Chapter 5: Software

### **Software Driven DC DAC Mode:**

There are two broad categories of software driven DAC usage: synchronous, or simultaneous, and asynchronous, or “automatic.” Simultaneous mode is so named because all DACs will switch from their old voltage (or current) output levels to their newly programmed levels simultaneously, and synchronously with an event.

### **Asynchronous:**

To use the DACs simply write desired count values to the DACs themselves, via Base + 0 through Base + E. The card powers up in this mode, so no other registers need to be manipulated.

# Chapter 6: Connector Pinouts

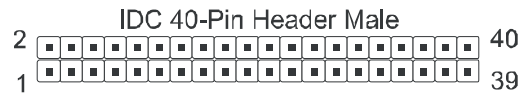

**Table 6-1: Connector P1, 40-pin Male IDC Header**

| Pin | Function | Pin | Function             |
|-----|----------|-----|----------------------|
| 1   | Ground   | 2   | DAC 0 Voltage Output |
| 3   |          | 4   | DAC 0 4-20mA Output  |
| 5   |          | 6   | DAC 1 Voltage Output |
| 7   |          | 8   | DAC 1 4-20mA Output  |
| 9   |          | 10  | DAC 2 Voltage Output |
| 11  |          | 12  | DAC 2 4-20mA Output  |
| 13  |          | 14  | DAC 3 Voltage Output |
| 15  |          | 16  | DAC 3 4-20mA Output  |
| 17  |          | 18  | DAC 4 Voltage Output |
| 19  |          | 20  | DAC 4 4-20mA Output  |
| 21  |          | 22  | DAC 5 Voltage Output |
| 23  |          | 24  | DAC 5 4-20mA Output  |
| 25  |          | 26  | DAC 6 Voltage Output |
| 27  |          | 28  | DAC 6 4-20mA Output  |
| 29  |          | 30  | DAC 7 Voltage Output |
| 31  |          | 32  | DAC 7 4-20mA Output  |
| 33  |          | 34  | +12 Volts Fused      |
| 35  | 4.096V   | 36  | +5 Volts Fused       |
| 37  | Ground   | 38  | n.c.                 |
| 39  | n.c.     | 40  | n.c.                 |

Note that pin 35 will be 0V if bit 6 of Control Register 2 is LOW.

Note also that pins 38, 39, and 40 are unused, such that connection via a standard 37-Pin DSub connector is simplified.

IDC 10-Pin Header Male



**Table 6-2:** Connector P2, 10-pin Male IDC Header

| Pin | Function          | Pin | Function         |
|-----|-------------------|-----|------------------|
| 1   | Load DAC (output) | 2   | N/C              |
| 3   | N/C               | 4   | Counter 0 Output |
| 5   | Ground            | 6   | Ground           |
| 7   | N/C               | 8   | N/C              |
| 9   | N/C               | 10  | N/C              |

Pin 1, Conversion Trigger, output

Every time the DACs are updated a very short low-going pulse will be generated here. (<100nS).

Pin 4, Clock Tick, output

This is the output of counter/timer 0. The user may program this 16-bit count-down timer to generate a tick or a square wave etc. (see appendix B).

Pins 5 and 6 are connected to the ground.

IDC 8-Pin Header Male

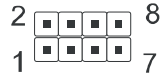

**Table 6-3: Connector P4, 8-pin Male IDC Header**

| Pin | Signal | Pin | Signal |
|-----|--------|-----|--------|
| 1   | Ground | 2   | n.c.   |
| 3   |        | 4   | +12V   |
| 5   |        | 6   | n.c.   |
| 7   |        | 8   | n.c.   |

The board does not require +12V but the user's 4-20mA circuit might. +12V is brought to pin 34 of connector P1 through a resettable fuse. This +12V may come from the PC/104 bus or from an external source. If the voltage comes from the PC/104 bus then a jumper should be placed on the pins of JP32 (next to P4) labeled LCL (local). If the voltage comes from a source connected to P4 then a jumper should be placed on the pins of JP32 labeled EXT. Note that if the voltage for the user's 4-20mA circuit comes from an external source that it isn't limited to 12V.

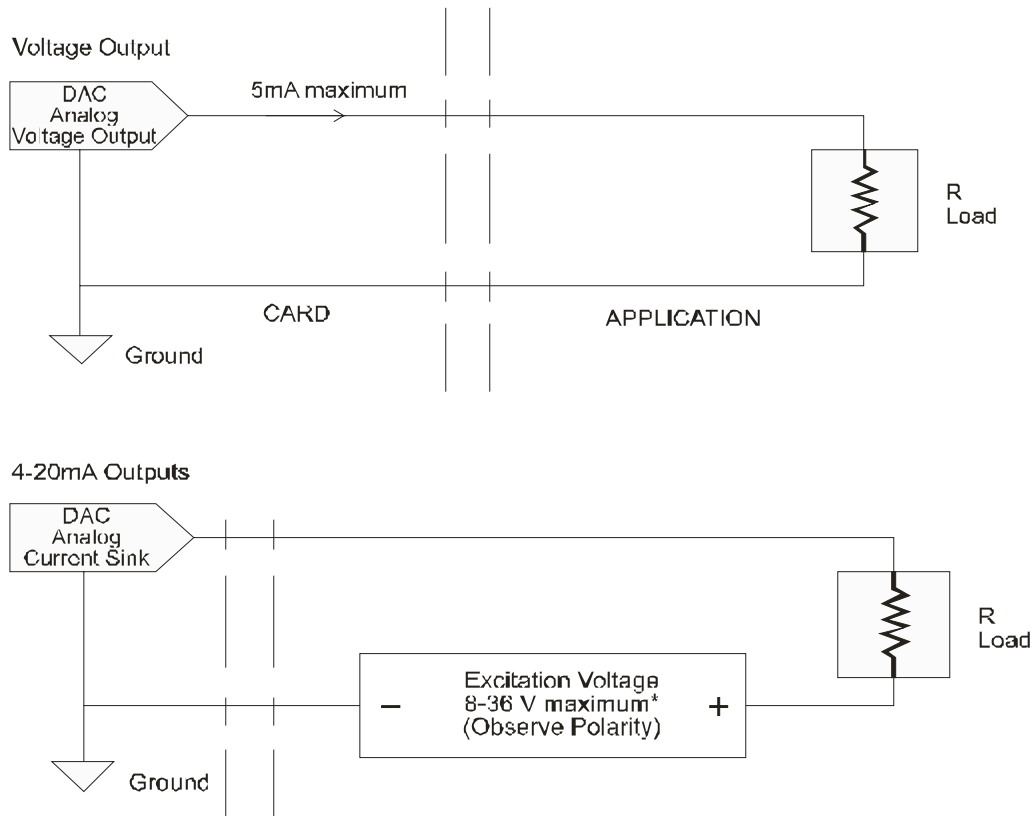

**Figure 6-1: Signal Connection**

# Appendix A: Technical Specifications

## ANALOG OUTPUTS

- 8 Channels
- 10 $\mu$ S per conversion, all channels simultaneously
- 12 Bit Resolution
- Output Ranges, 0-5V 0-10V +5V +10V
- Eight 4-20mA current sink outputs (external 8 to 36VDC excitation required)
- +2 counts D/AC Relative Accuracy (typical)
- 8 $\mu$ S D/AC Settling Time (typical, to 3/4 scale)
- +0.4 % of Full Scale D/AC Offset Error (typical)
- +0.1 % of Full Scale D/AC Gain Error (typical)
- Drive Capability of 5mA per channel, Outputs are Short-Circuit Protected
- 30mA cumulative total drive from all D/ACs
- 4.096V Voltage Reference

## Counter/Timer

- Type 82C54
- 3 x 16-Bit Down-Counters
- Counter 0 is an IRQ source (clock-tick interrupt) and frequency source (counter 0 output is available at P2 connector pin 4)
- 10MHz Input Clock Frequency

## General

- +5V @ 210mA Power Consumption (typical, no load on the outputs)
- On-board DC/DC Converter allows operation on +5V Power
- Interrupt requests may be generated on channels 3-7, 10-12 and 14-15
- Environment Tolerance: 0-70C, 5% to 95% Humidity (non-condensing)  
(-40 to +85C available with special order)

# Appendix B: 82C54 Counter Timer Operation

The board contains one type 8254 programmable counter/timer. The 8254 consists of three independent, 16-bit, presetable down-counters. Each counter can be programmed to any count between 2 and 65,535 in binary format, depending on the mode chosen. The programmed value is a divisor, the output frequency equals the input frequency divided by the programmed value.

In this manual these three counter/timers are designated Counter/Timer 0, Counter/Timer 1, and Counter/Timer 2.

Counter/Timer 0 is a 16-bit counter with a 10MHz input clock. The output of Counter/Timer 0 is available at connector P2 pin 4. The gate signal for counters 1 & 2 is controlled via software at bit 1 (HIGH = off, LOW = count enabled = power-on default) of the register at Base + 10h. Counter/Timers 1 and 2 are concatenated by the card to form a single 32-bit counter. The input of the counter is fixed at 2MHz. The output of is available at connector P2 pin 1.

## OPERATIONAL MODES

The 8254 modes of operation are described in the following paragraphs to familiarize you with the versatility and power of this device. For those interested in more detailed information, a full description of the 8254 programmable interval timer can be found in the Intel (or equivalent manufacturers) data sheets. The following conventions apply for use in describing operation of the 8254 :

|                  |  |
|------------------|--|
| Clock:           | A positive pulse into the counter's clock input. |
| Trigger:         | A rising edge input to the counter's gate input. |
| Counter Loading: | Programming of a binary count into the counter.  |

### Mode 0: Pulse on Terminal Count

After the counter is loaded, the output is set low and will remain low until the counter decrements to zero. The output then goes high and remains high until a new count is loaded into the counter. A trigger enables the counter to start decrementing.

### Mode 1: Retriggerable One-Shot

The output goes low on the clock pulse following a trigger to begin the one-shot pulse and goes high when the counter reaches zero. Additional triggers result in reloading the count and starting the cycle over. If a trigger occurs before the counter decrements to zero, a new count is loaded. Thus, this forms a re-triggerable one-shot. In mode 1, a low output pulse is provided with a period equal to the counter count-down time.

### Mode 2: Rate Generator

This mode provides a divide-by-N capability where N is the count loaded into the counter. When triggered, the counter output goes low for one clock period after N counts, reloads the initial count, and the cycle starts over. This mode is periodic, the same sequence is repeated indefinitely until the gate input is brought low.

### Mode 3: Square Wave Generator

This mode operates periodically like mode 2. The output is high for half of the count and low for the other half. If the count is even, then the output is a symmetrical square wave. If the count is odd, then the output is high for  $(N+1)/2$  counts and low for  $(N-1)/2$  counts. Periodic triggering or frequency synthesis are two possible applications for this mode. Note that in this mode, to achieve the square wave, the counter decrements by two for the total loaded count, then reloads and decrements by two for the second part of the wave form.

### Mode 4: Software Triggered Strobe

This mode sets the output high and, when the count is loaded, the counter begins to count down. When the counter reaches zero, the output will go low for one input period. The counter must be reloaded to repeat the cycle. A low gate input will inhibit the counter. This mode can be used to provide a delayed software trigger for initiating A/D conversions.

### Mode 5: Hardware Triggered Strobe

In this mode, the counter will start counting after the rising edge of the trigger input and will go low for one clock period when the terminal count is reached. The counter is retriggerable. The output will not go low until the full count after the rising edge of the trigger.

## PROGRAMMING

On this card the 8254 counters occupy the following addresses (hex):

Base Address + 14: Read/Write Counter 0  
 Base Address + 15: Read/Write Counter 1  
 Base Address + 16: Read/Write Counter 2  
 Base Address + 17: Write to Counter Control register

The counters are programmed by writing a control byte into a counter control register. The control byte specifies the counter to be programmed, the counter mode, the type of read/write operation, and the modulus. The control byte format is as follows:

|     |     |     |     |    |    |    |     |
|-----|-----|-----|-----|----|----|----|-----|
| B7  | B6  | B5  | B4  | B3 | B2 | B1 | B0  |
| SC1 | SC0 | RW1 | RW0 | M2 | M1 | M0 | BCD |

SC0-SC1: These bits select the counter that the control byte is destined for.

| SC1 | SC0 | Function          |
|-----|-----|-------------------|
| 0   | 0   | Program Counter 0 |
| 0   | 1   | Program Counter 1 |
| 1   | 0   | Program Counter 2 |
| 1   | 1   | Read/Write Cmd.*  |

\* See Chapter on READING AND LOADING THE COUNTERS.

RW0-RW1: These bits select the read/write mode of the selected counter.

| RW1 | RW0 | Counter Read/Write Function      |
|-----|-----|----------------------------------|
| 0   | 0   | Counter Latch Command            |
| 0   | 1   | Read/Write LS Byte               |
| 1   | 0   | Read/Write MS Byte               |
| 1   | 1   | Read/Write LS Byte, then MS Byte |

M0-M2: These bits set the operational mode of the selected counter.

| MODE | M2 | M1 | M0 |
|------|----|----|----|
| 0    | 0  | 0  | 0  |
| 1    | 0  | 0  | 1  |
| 2    | X  | 1  | 0  |
| 3    | X  | 1  | 1  |
| 4    | 1  | 0  | 0  |
| 5    | 1  | 0  | 1  |

BCD: Set the selected counter to count in binary (BCD = 0) or BCD (BCD = 1).

## READING AND LOADING THE COUNTERS

If you attempt to read the counters on the fly when there is a high input frequency, you will most likely get erroneous data. This is partly caused by carries rippling through the counter during the read operation. Also, the low and high bytes are read sequentially rather than simultaneously and, thus, it is possible that carries will be propagated from the low to the high byte during the read cycle.

To circumvent these problems, you can perform a counter-latch operation in advance of the read cycle. To do this, load the RW1 and RW2 bits with zeroes. This instantly latches the count of the selected counter (selected via the SC1 and SC0 bits) in a 16-bit hold register. (An alternative method of latching counter(s) which has an additional advantage of operating simultaneously on several counters is by use of a readback command to be discussed later.) A subsequent read operation on the selected counter returns the held value. Latching is the best way to read a counter on the fly without disturbing the counting process. You can only rely on directly read counter data if the counting process is suspended while reading, by bringing the gate low, or by halting the input pulses.

For each counter you must specify in advance the type of read or write operation that you intend to perform. You have a choice of loading/reading (a) the high byte of the count, or (b) the low byte of the count, or (c) the low byte followed by the high byte. This last is of the most general use and is selected for each counter by setting the RW1 and RW0 bits to ones. Of course, subsequent read/load operations must be performed in pairs in this sequence or the sequencing flip-flop in the 8254 chip will get out of step.

The readback command byte format is:

|    |    |     |     |    |    |    |    |
|----|----|-----|-----|----|----|----|----|
| B7 | B6 | B5  | B4  | B3 | B2 | B1 | B0 |
| 1  | 1  | CNT | STA | C2 | C1 | C0 | 0  |

- CNT: When is 0, latches the counters selected by bits C0-C2.  
 STA: When is 0, returns the status byte of counters selected by C0-C2.  
 C0, C1, C2: When high, select a particular counter for readback. C0 selects Counter 0, C1 selects Counter 1, and C2 selects Counter 2.

You can perform two types of operations with the readback command. When CNT=0, the counters selected by C0 through C2 are latched simultaneously. When STA=0, the counter status byte is read when the counter I/O location is accessed. The counter status byte provides information about the current output state of the selected counter and its configuration. The status byte returned if STA=0 is:

|     |    |     |     |    |    |    |     |
|-----|----|-----|-----|----|----|----|-----|
| B7  | B6 | B5  | B4  | B3 | B2 | B1 | B0  |
| OUT | NC | RW1 | RW2 | M2 | M1 | M0 | BCD |

- OUT: Current state of counter output pin.  
 NC: Null count. This indicates when the last count loaded into the counter register has actually been loaded into the counter itself. The exact time of load depends on the configuration selected. Until the count is loaded into the counter itself, it cannot be read.  
 RW1, RW0: Read/Write command.  
 M2, M1, M0: Counter mode.  
 BCD: BCD = 0 is binary mode, otherwise counter is in BCD mode.

If both STA and CNT bits in the readback command byte are set low and the RW1 and RW0 bits have both been previously set high in the counter control register (thus selecting two-byte reads), then reading a selected counter address location will yield:

- 1st Read: Status byte
- 2nd Read: Low byte of latched data
- 3rd Read: High byte of latched data

After any latching operation of a counter, the contents of its hold register must be read before any subsequent latches of that counter will have any effect. If a status latch command is issued before the hold register is read, then the first read will read the status, not the latched value.

## Customer Comments

If you experience any problems with this manual or just want to give us some feedback, please email us at: ***manuals@acesio.com***. Please detail any errors you find and include your mailing address so that we can send you any manual updates.



10623 Roselle Street, San Diego CA 92121  
Tel. (858)550-9559 FAX (858)550-7322  
[www.acesio.com](http://www.acesio.com)